

Quick & Easy

ORIGAMI CHRISTMAS



**TOSHIE
TAKAHAMA**

Origami Symbols

Outline & crease

Concealed part or previous position

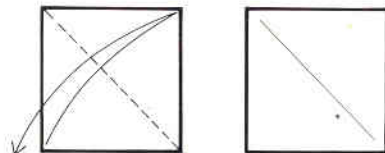

Fold and unfold to crease

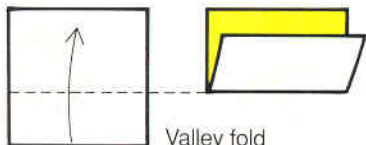

Valley fold

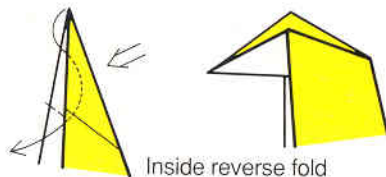

Inside reverse fold

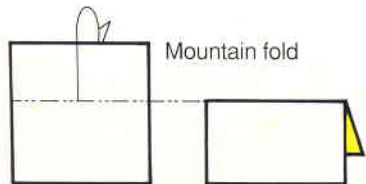

Mountain fold

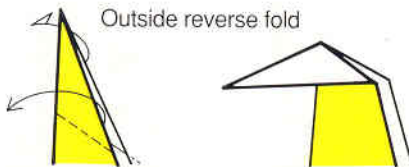

Outside reverse fold

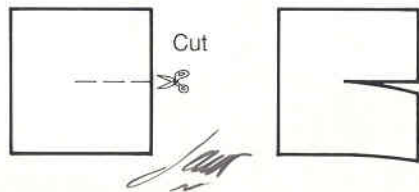
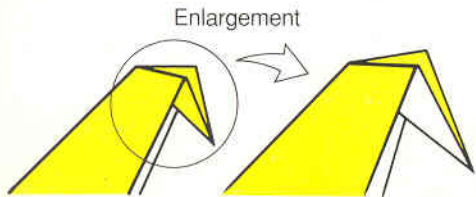
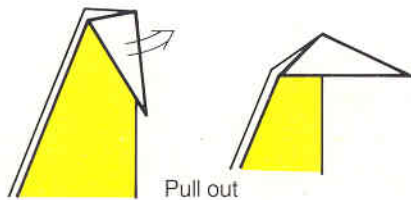
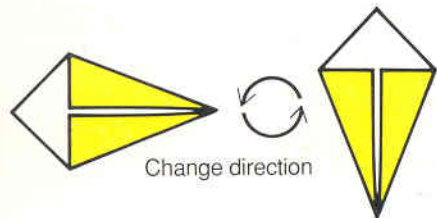
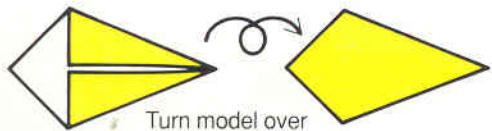

CANDY STICK

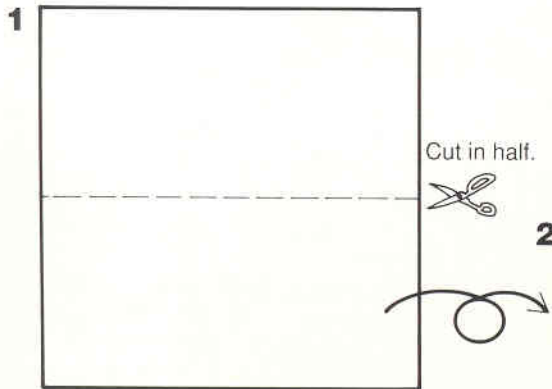

2

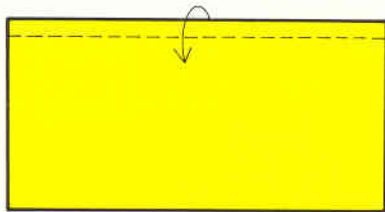

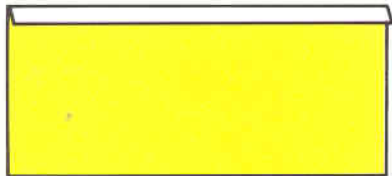
3**4****8**

Completed.

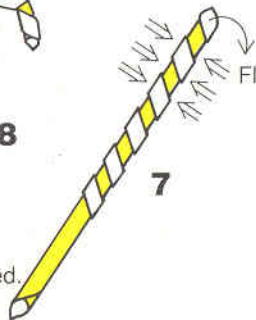
**7**

Flatten and bend.

Paste.

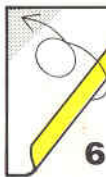
**6**

Roll tightly on the diagonal.

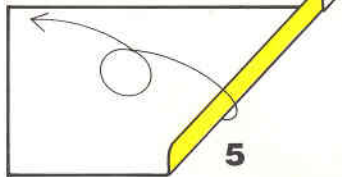
**5**

SNOWMAN

1

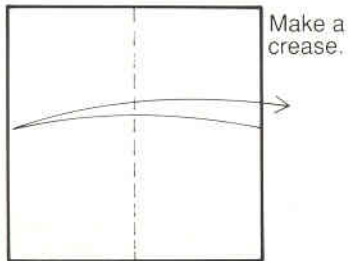

2

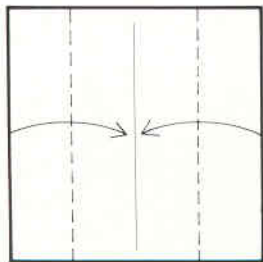

3

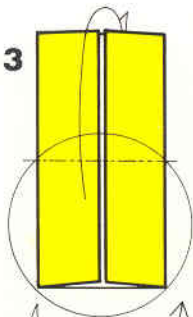

4

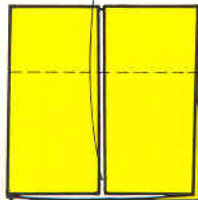

5

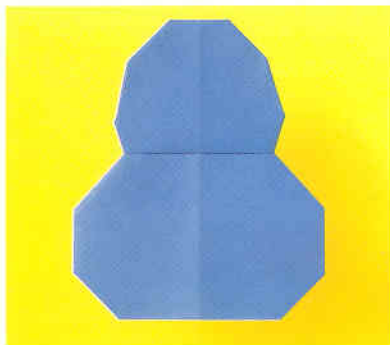
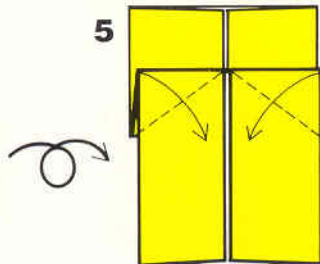

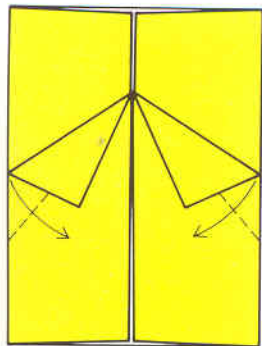

6

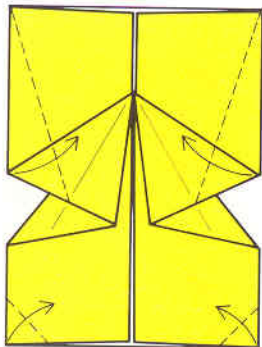

7

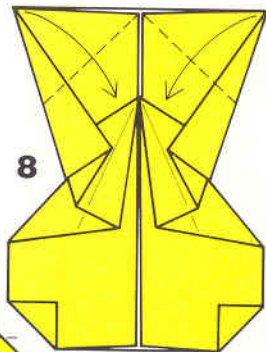

8

10

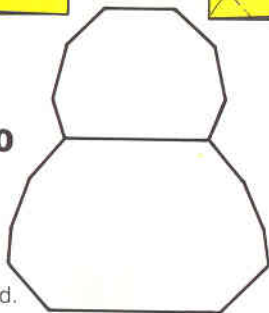

Completed.

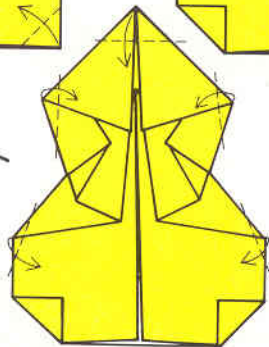

9

PARTY BOW

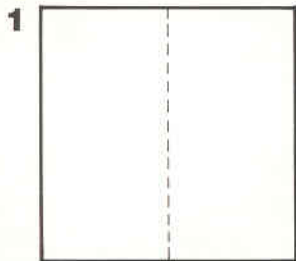

Cut in half. 

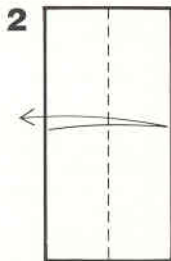

Make a crease.

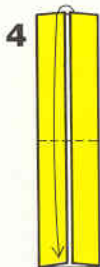
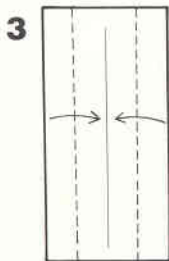
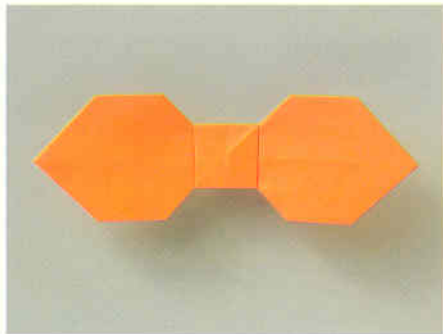

Make two creases.

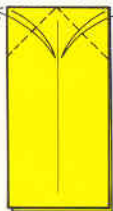

Push corners in.

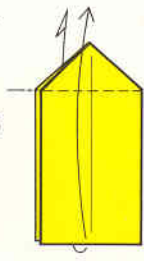
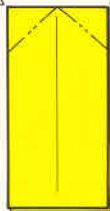

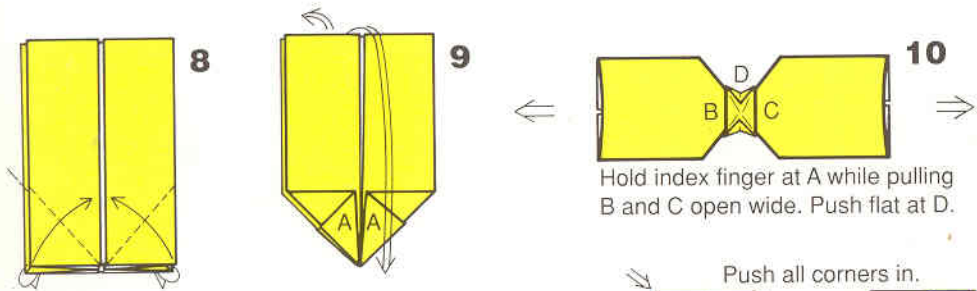

Hold index finger at A while pulling B and C open wide. Push flat at D.

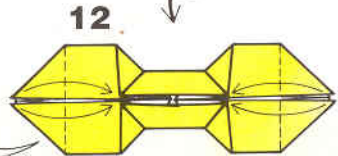
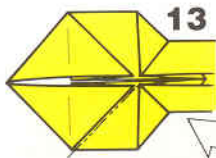
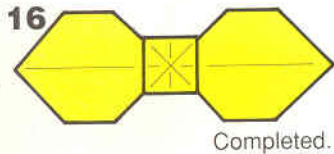
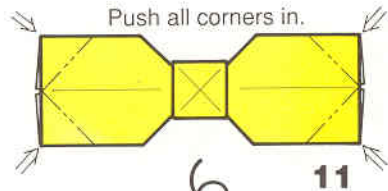
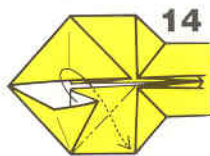
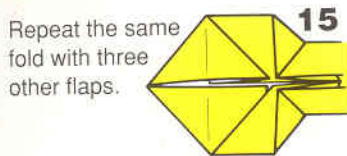

CANDLE

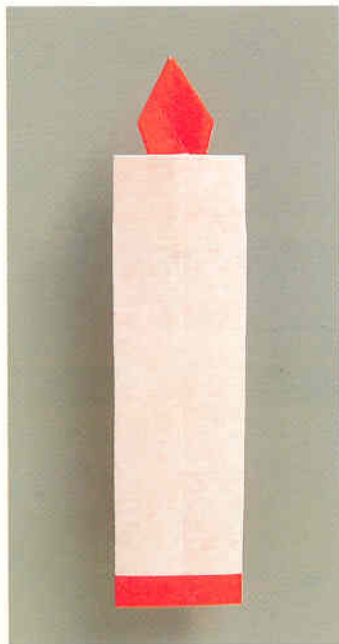
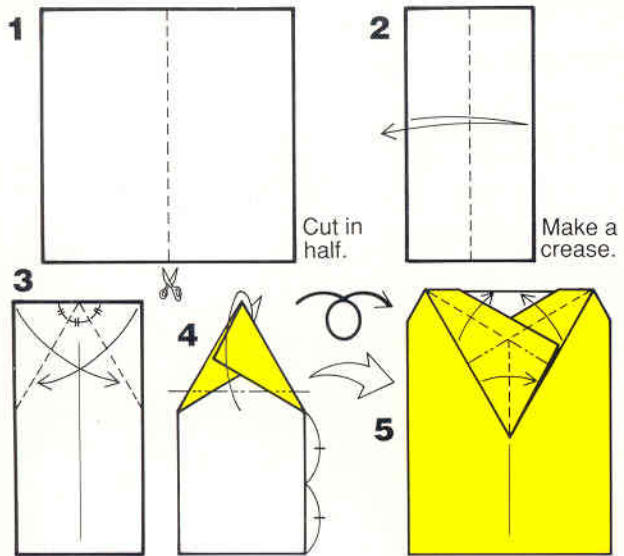

6

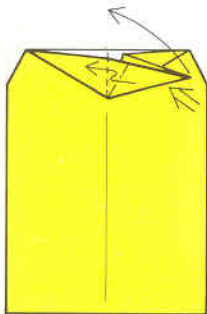

Squash.

7

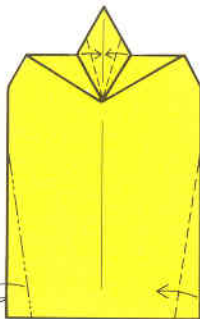

8

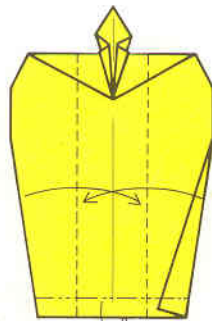

First fold bottom under.



11

Completed.



10



9



CHRISTMAS STOCKING

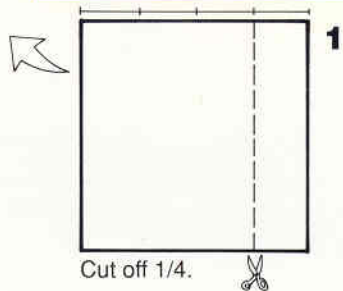
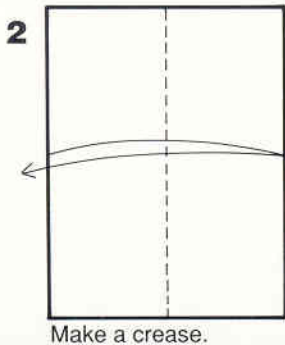
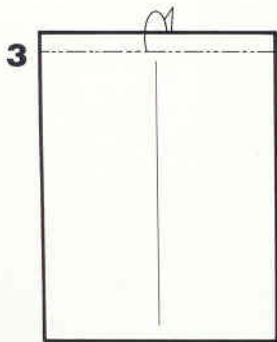

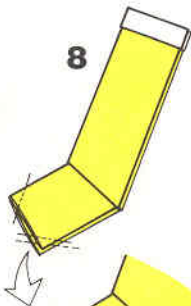
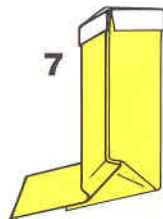
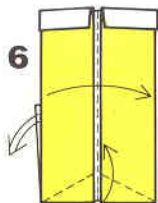
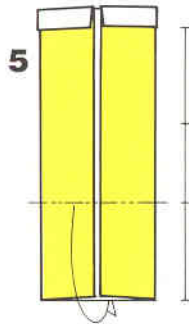
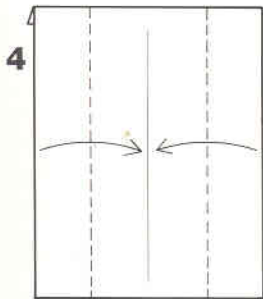

Push corner in.

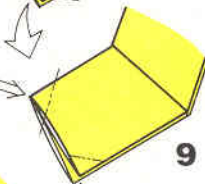

Push corner in
on one flap.

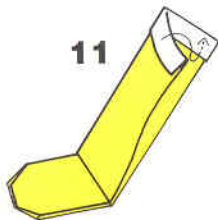
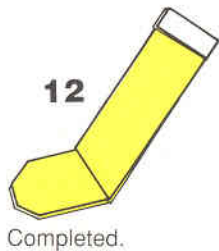

Tuck other flap
into indentation
made in step 9.

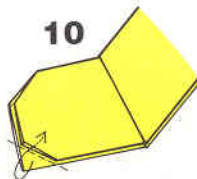

BALLOON

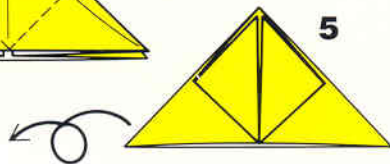
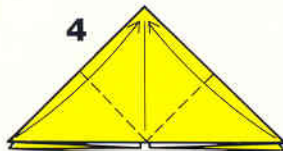
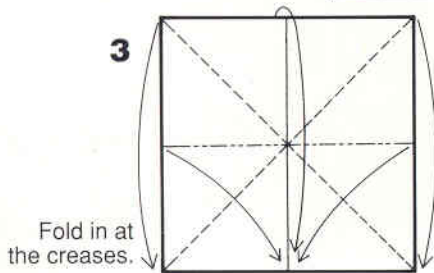
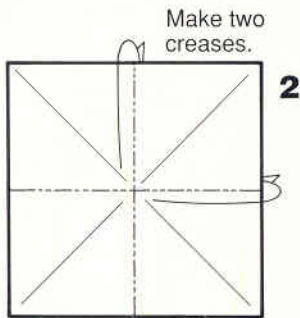
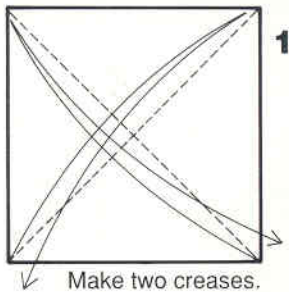

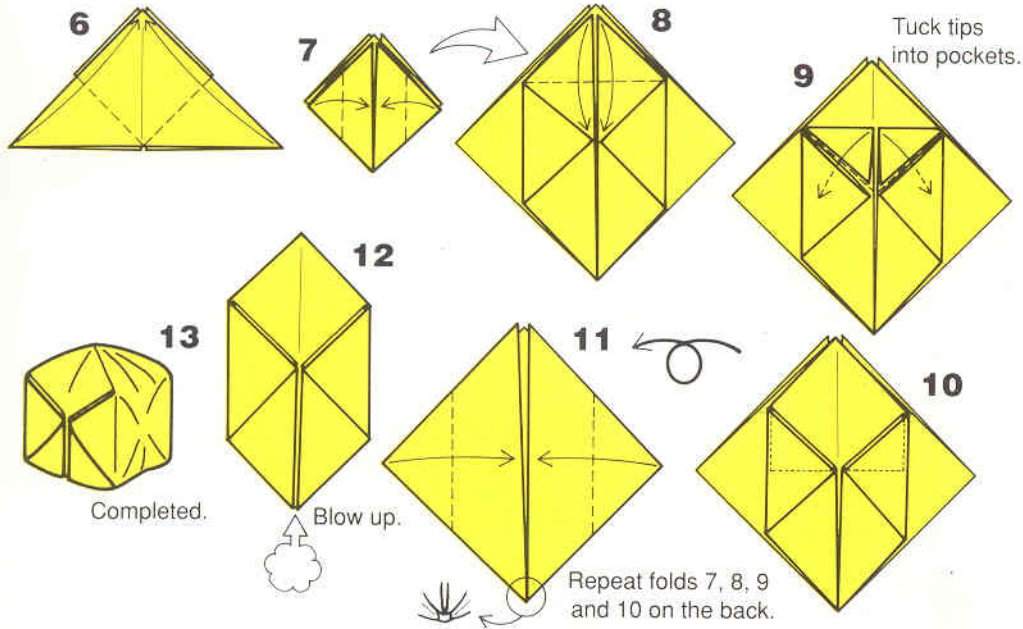

BELL

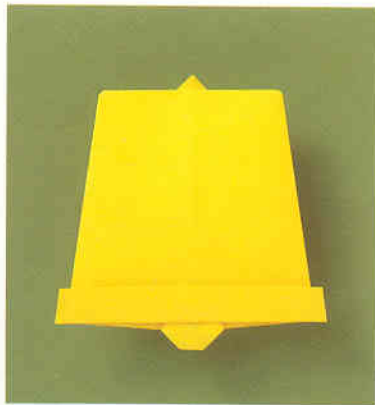
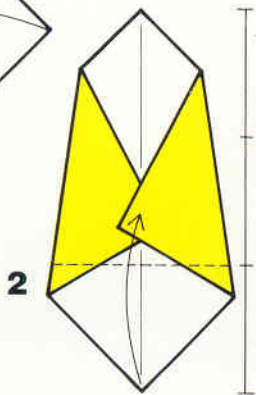
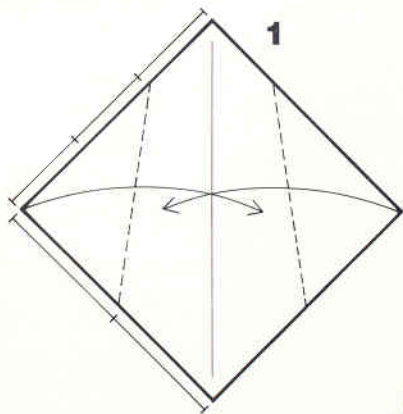

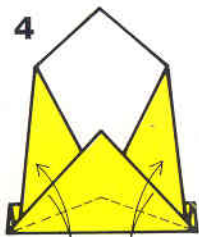
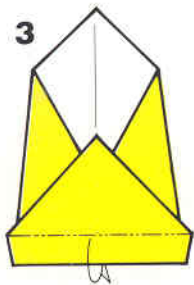

Make two creases.

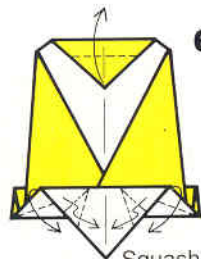
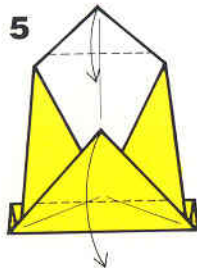

Squash to form shape in step 7.

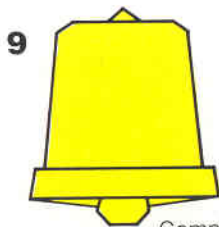

Completed.

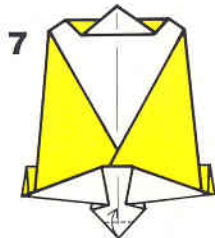
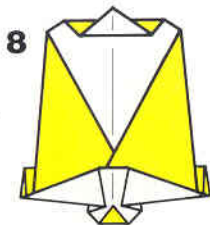

CHRISTMAS TREE

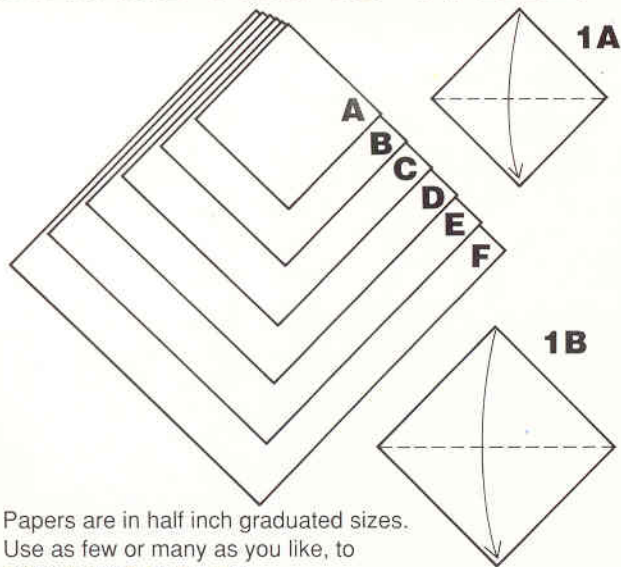

Papers are in half inch graduated sizes.
Use as few or many as you like, to
make a short or tall tree.



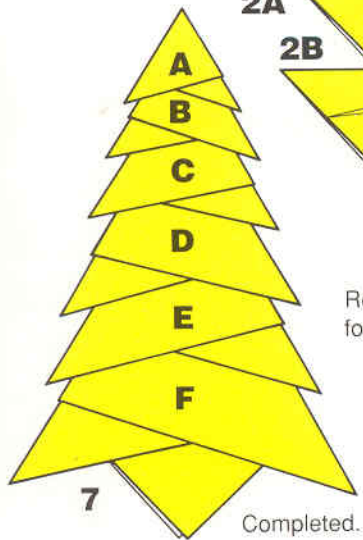

2A



2B

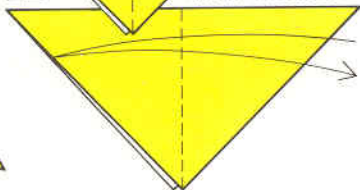

Make creases.

Repeat the same folds for C-F.

6



3A

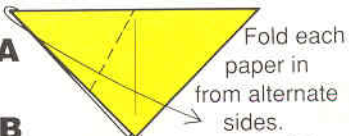

Fold each paper in from alternate sides.

3B

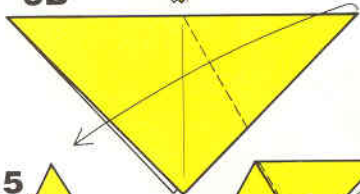

5

Insert and paste.



4A



4B

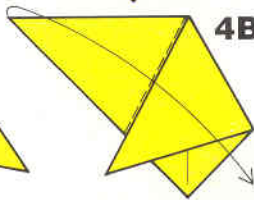

PAPER CHAIN

Making Links

Make a crease.

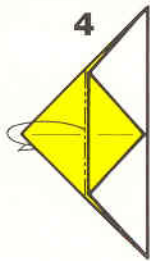
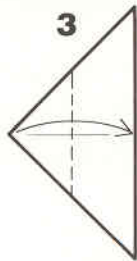
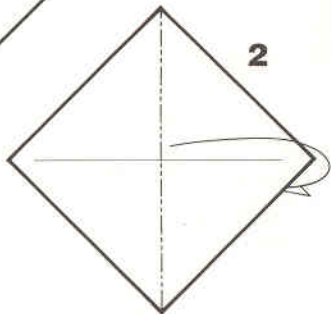
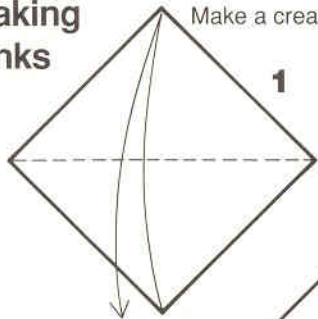

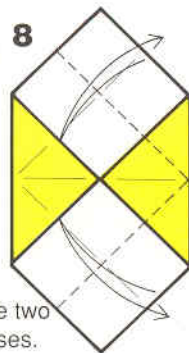
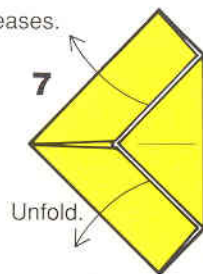
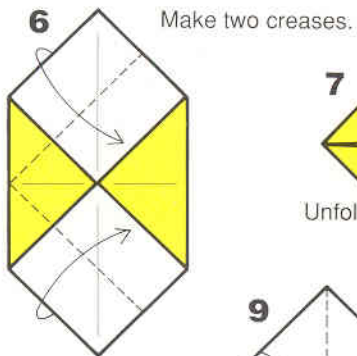
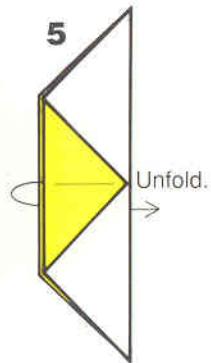

Make two creases.

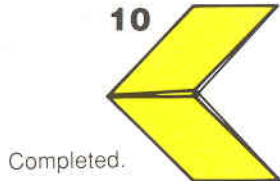
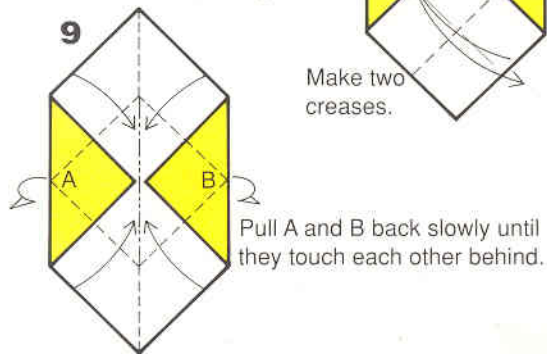

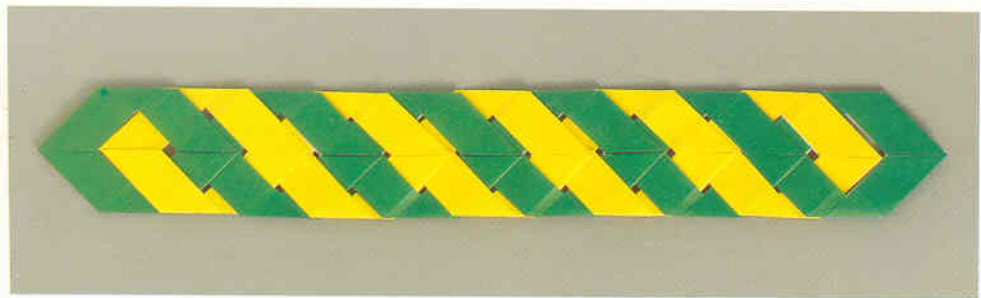
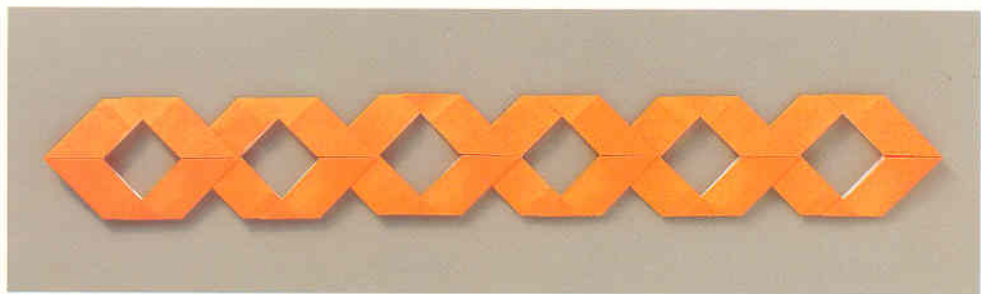

Joining Links

BASIC CHAIN

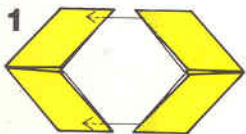

Insert and paste.

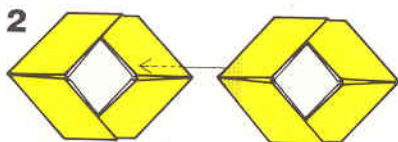

Insert and paste.

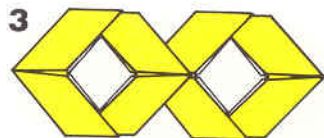

Completed.

DOUBLE CHAIN

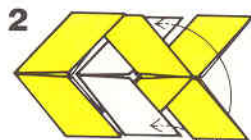
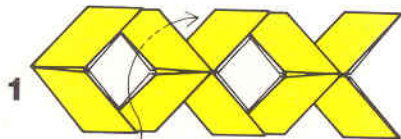

Insert and paste.

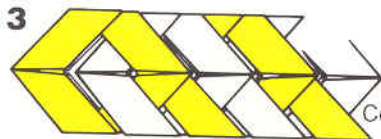

Completed.

CHURCH

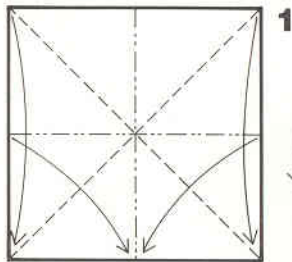

Make four creases.

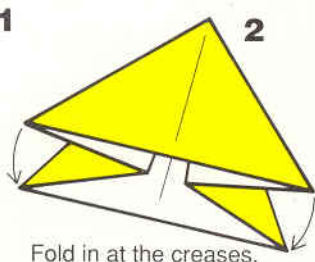

Fold in at the creases.

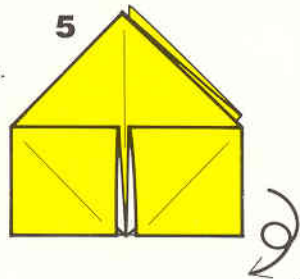
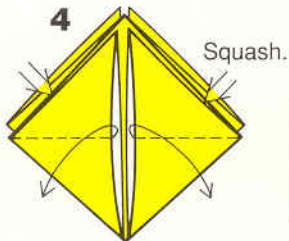
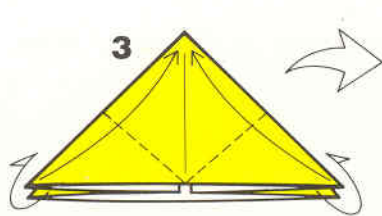

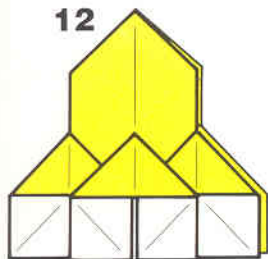
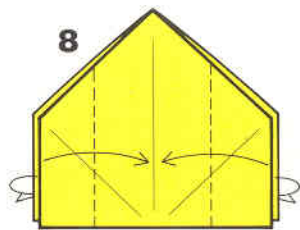
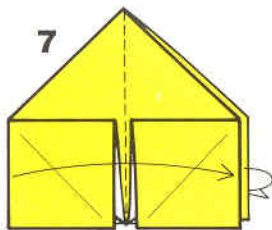
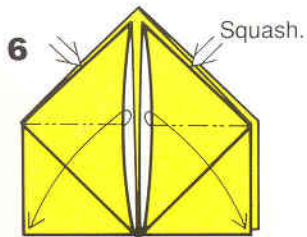

Completed.

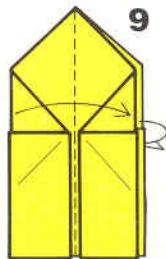
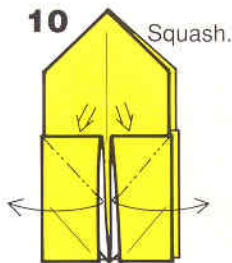
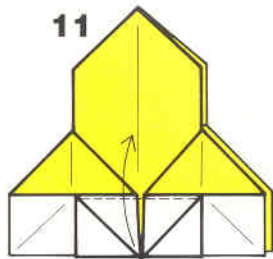

HEART

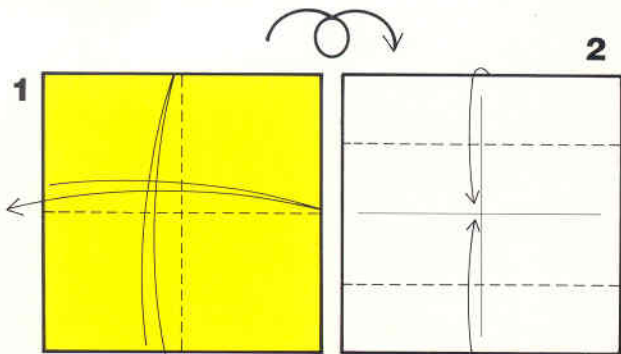

Make two
creases.

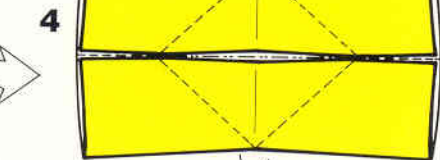
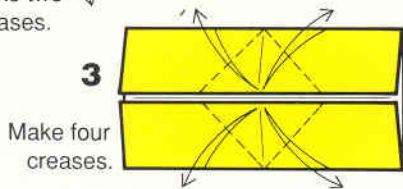

Fold along the creases.

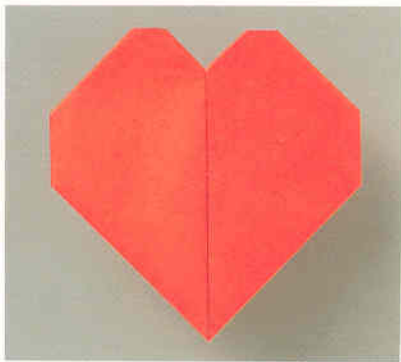

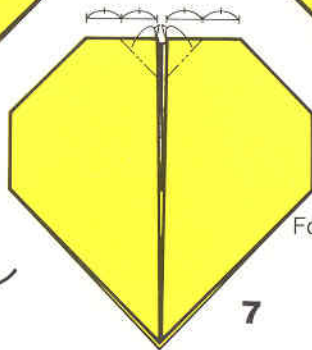
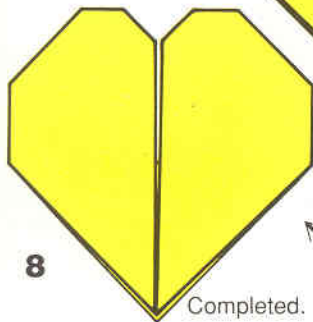
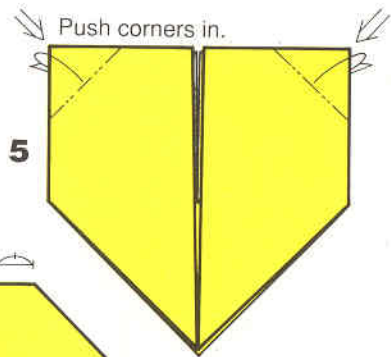
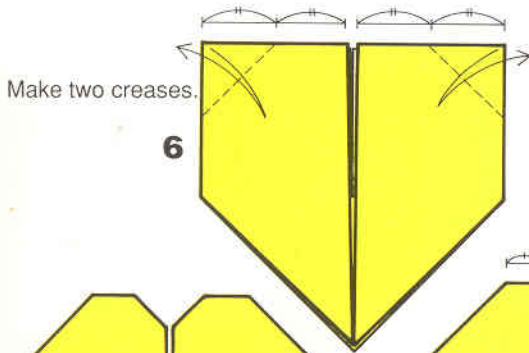

PONY

Make four creases.

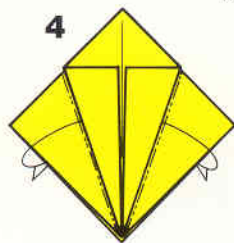
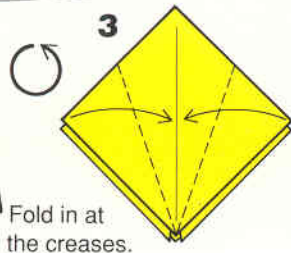
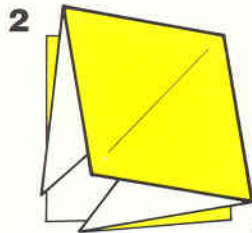
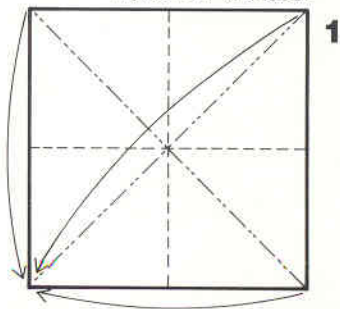

Make a crease at A.

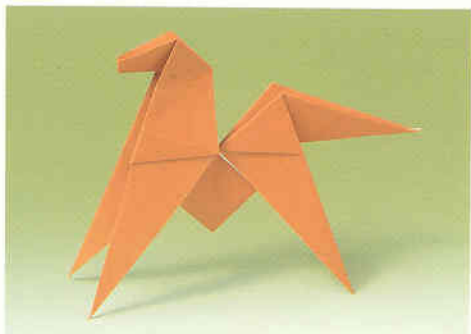
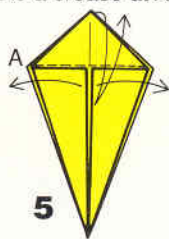

Cut only top and bottom flaps along dotted line, and stop at horizontal crease.

6

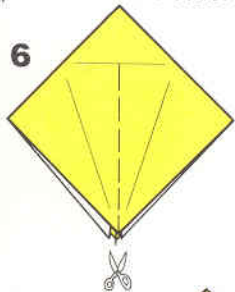

7

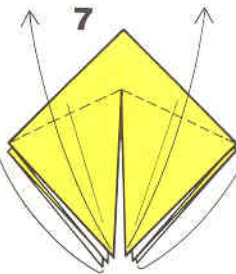

8

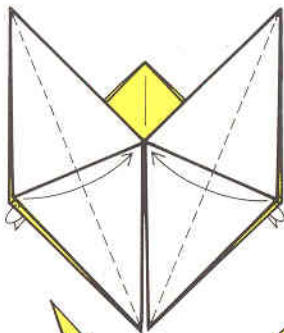

11

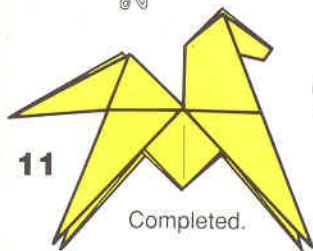

Completed.



10

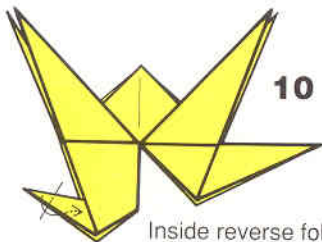

Inside reverse fold.

9

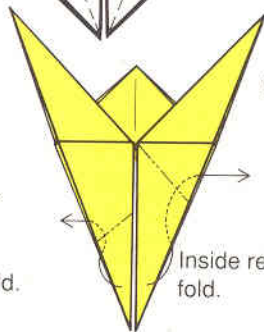

Inside reverse fold.

ANGEL

Cut off 1/4 of the square paper as in Christmas stocking.

(Based on a design by David Brill)



1 Make three creases.

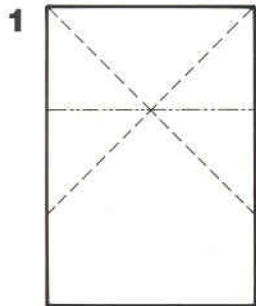

2 Fold in at the creases.

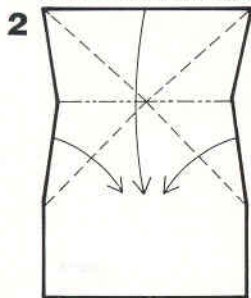

Lift all the flaps up.

5

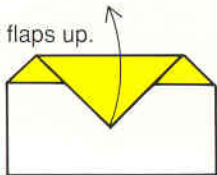

4

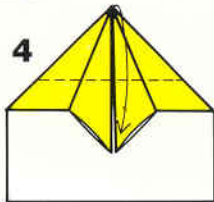

3

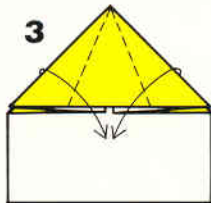

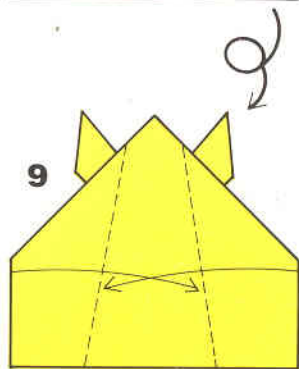
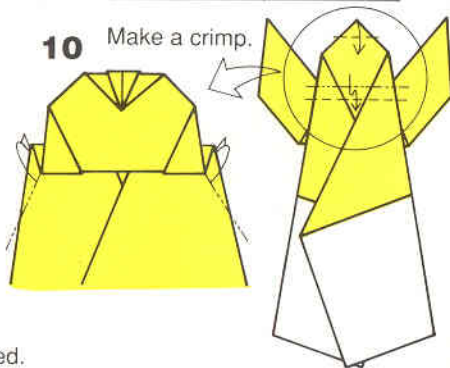
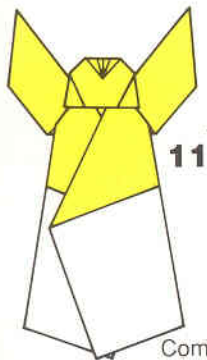
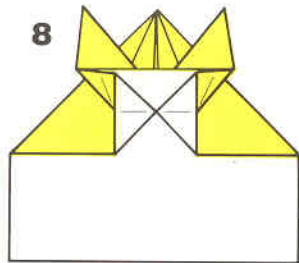
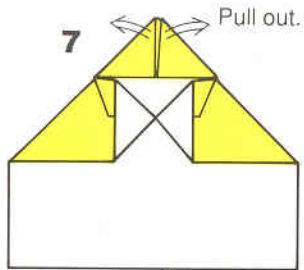
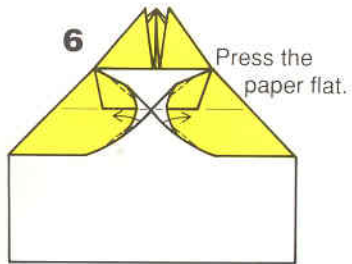

HOLLY

a) Leaf

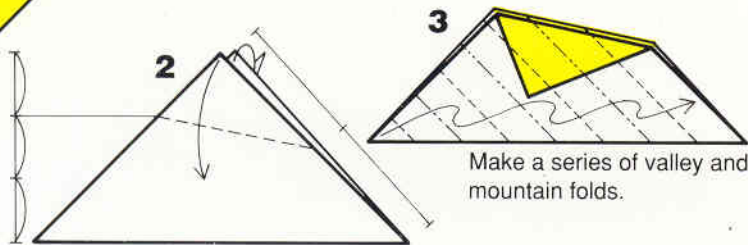
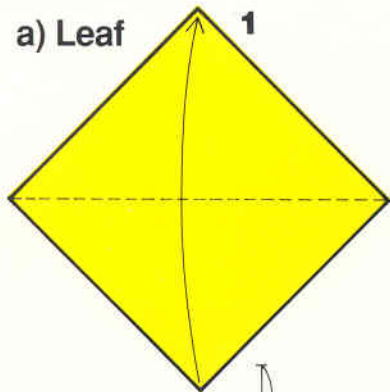

Make a series of valley and mountain folds.

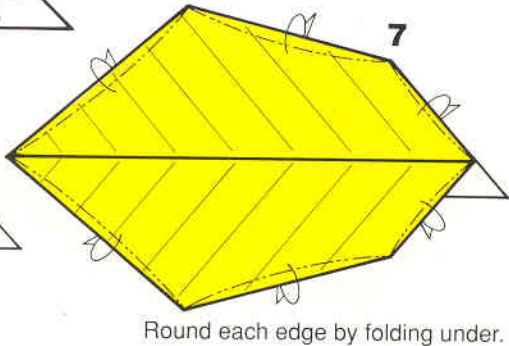
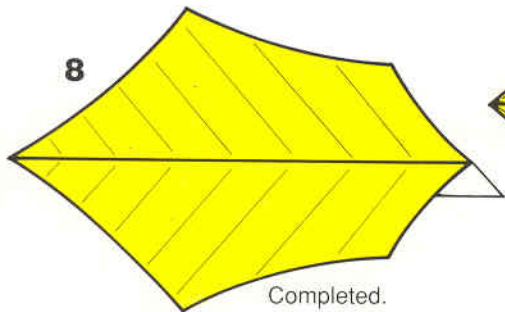
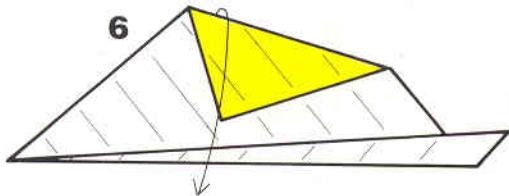
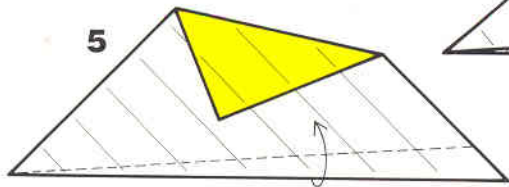

b) Berries

Use paper 2/3's size of leaf paper.

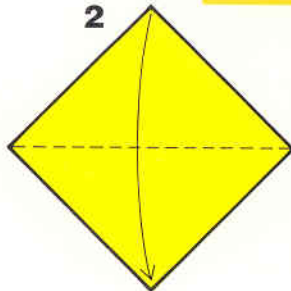
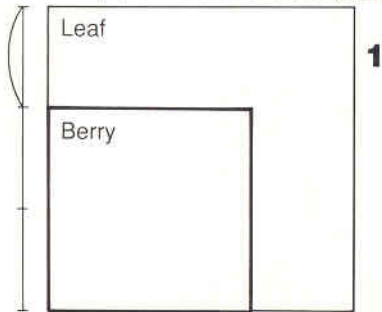

Make a crease.

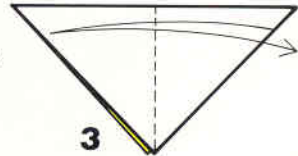

Make two creases.

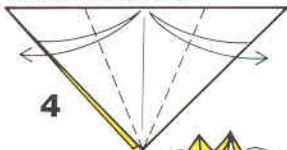

Make two creases.

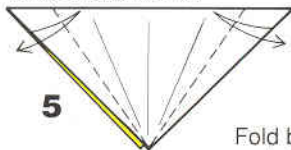

Outside reverse fold.

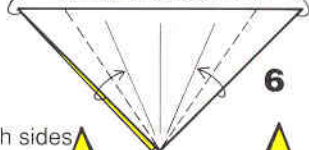

Fold both sides
into center.

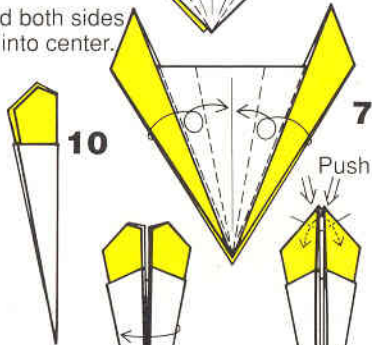

Push in.

10



8

12



11

Insert stems of
leaves into pockets
front and back.

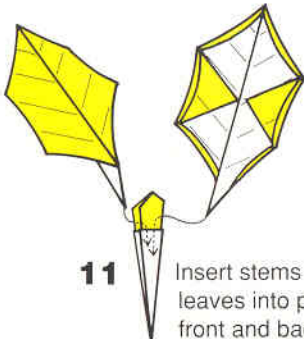

13

Completed.

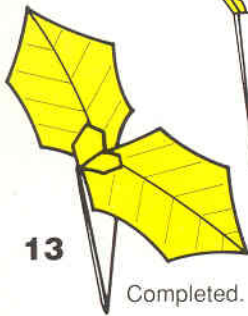

GIFT BOX

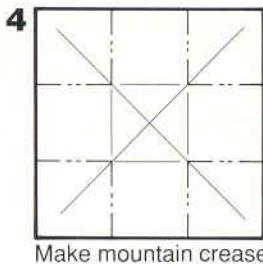
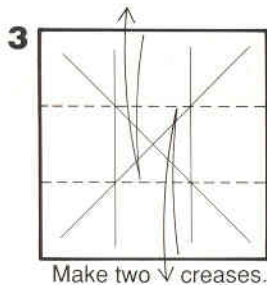
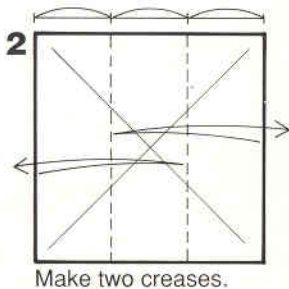
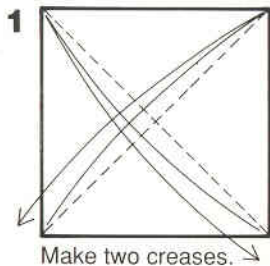

Make mountain creases on the eight dotted lines.

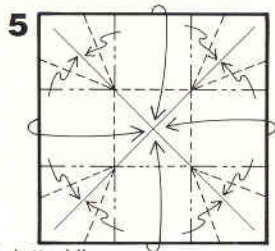

Repeat the same folds with the other three corners.

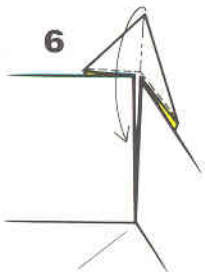

6

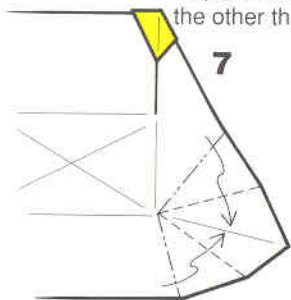

7

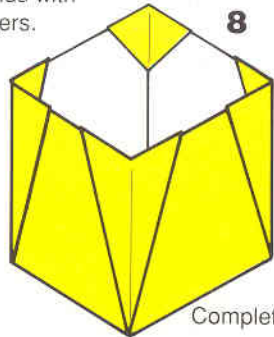

8

Completed.

Lid

1

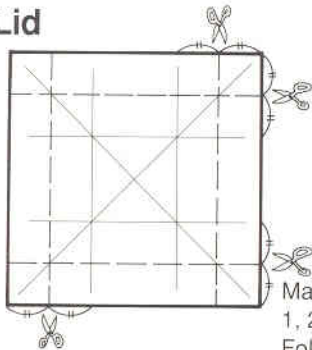

2

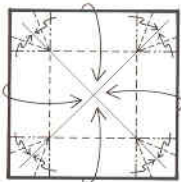

Make the same creases as in 1, 2, & 3. Cut along dotted lines. Fold corners as in 5, 6, & 7 above.

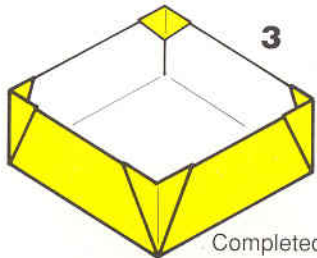

3

Completed.

STAR

1

See page 61 to make basic pentagon.

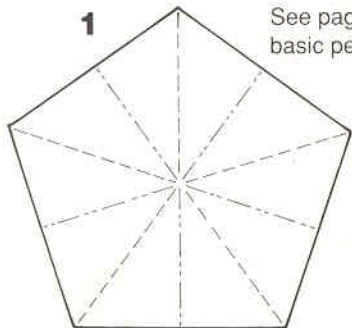

2



Make a crease.

3



Unfold.



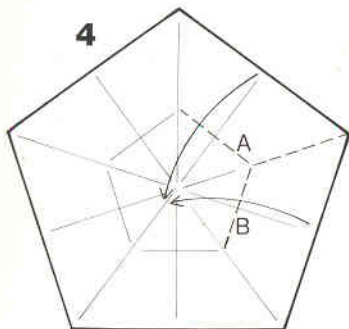

4
Push in at line A, then push in at line B.

Fold the resulting flap down flat to make a crease. Repeat four times in order to get the pattern of creases shown at right.

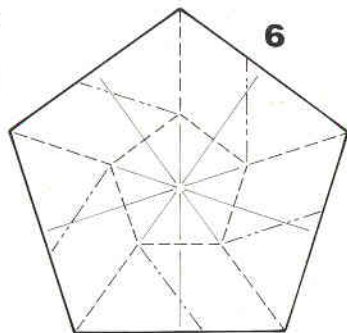
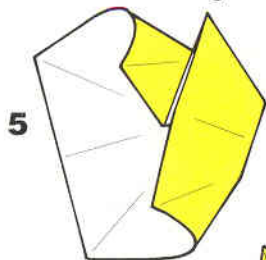

Completed.

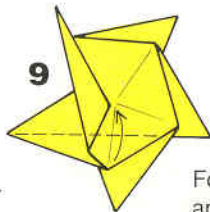

9
Fold the inner point in and repeat four times.

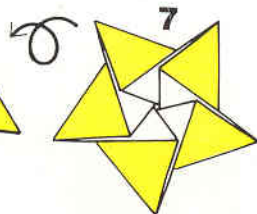
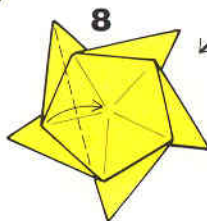

7
Fold in at the creases to make a star shape.

FLOWER

See page 61 to make basic pentagon.

Make five sharp creases.

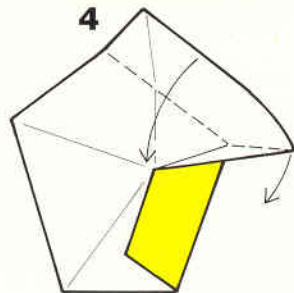
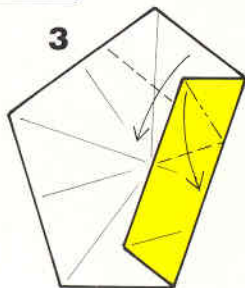
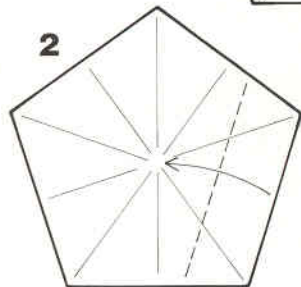
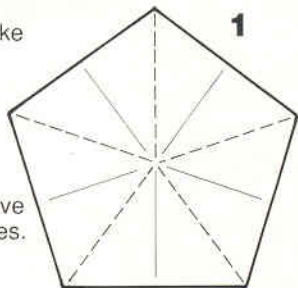

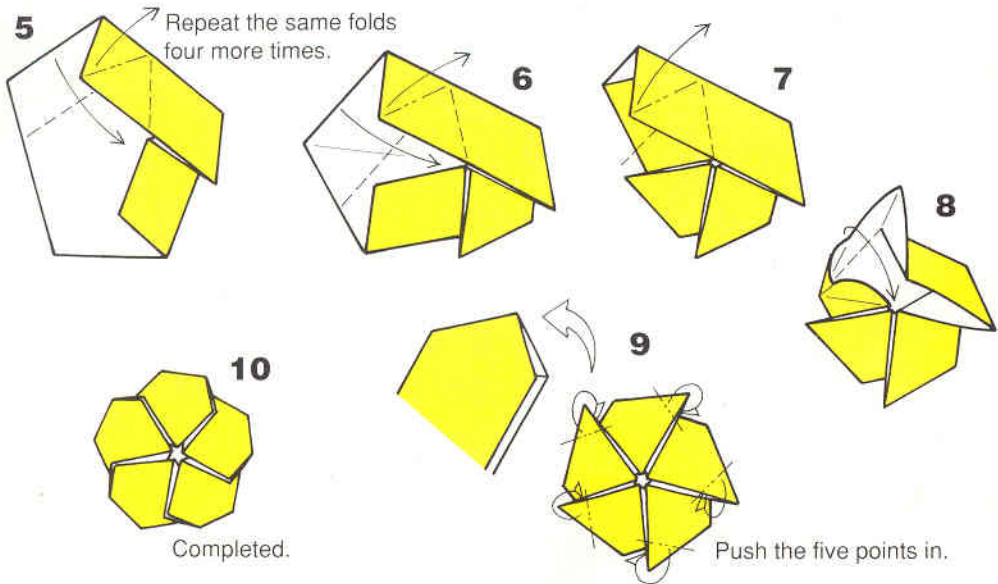

PINWHEEL

1

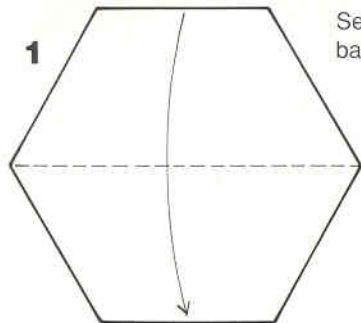

See page 61 to make basic hexagon.

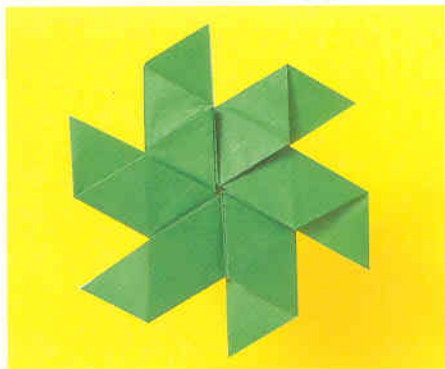

2

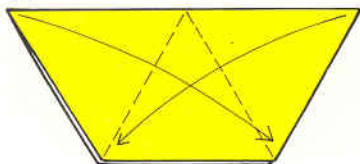

3

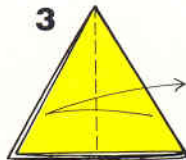

Make a crease.

4

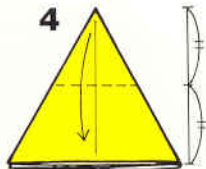



Unfold.

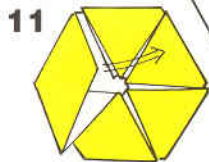
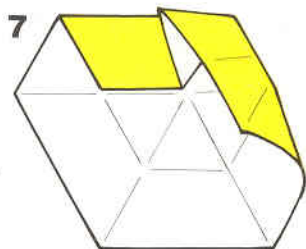
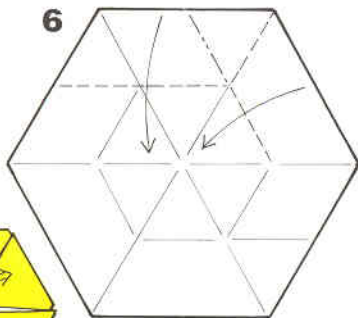

10

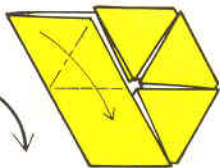

9

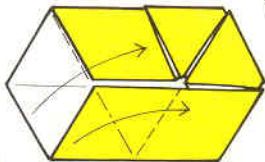

8

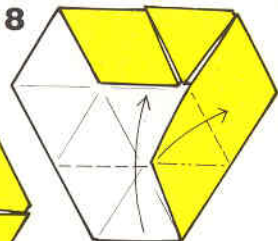

Repeat the same folds three more times.

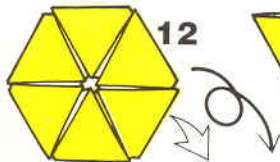

Turn model over before starting step 13.

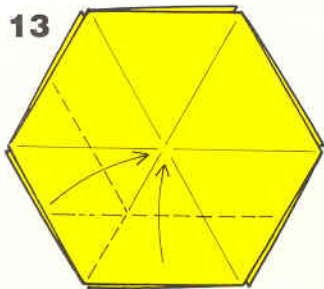

Repeat the same fold
four more times.

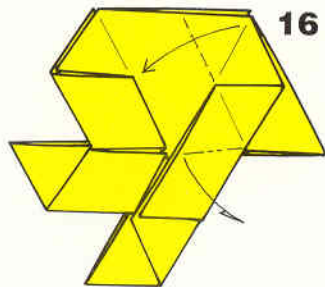
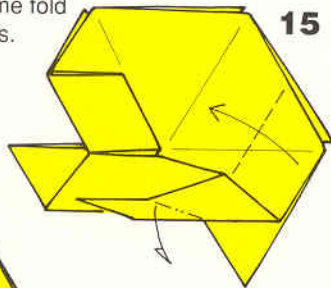
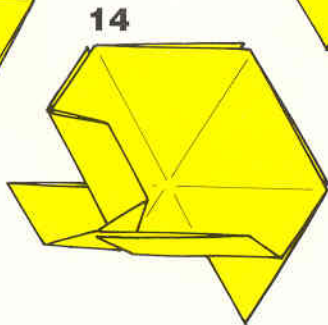

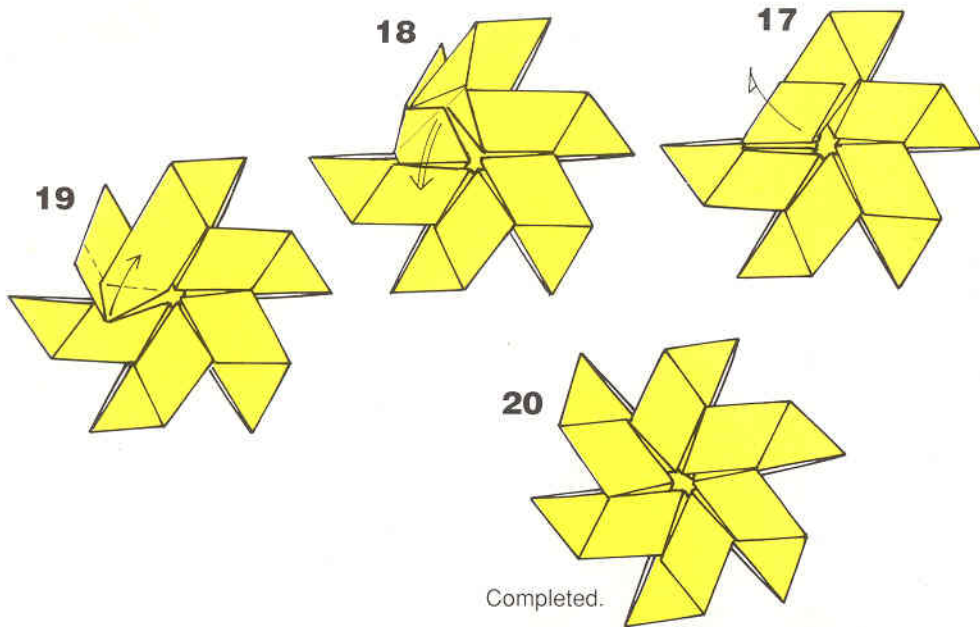

SNOWFLAKE

Begin with step 12 of Pinwheel.

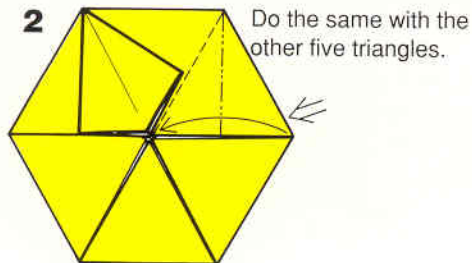
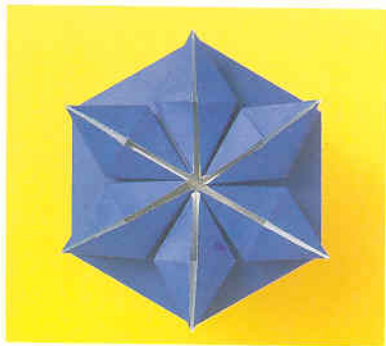
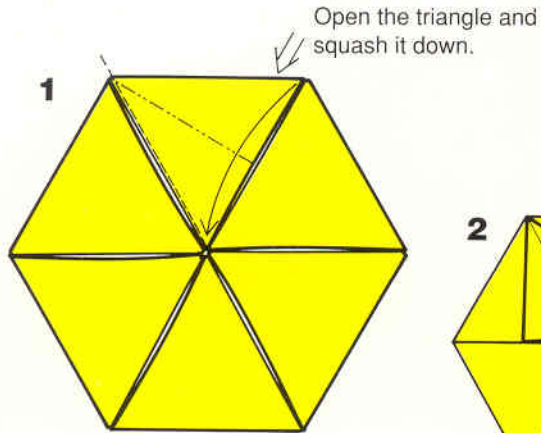

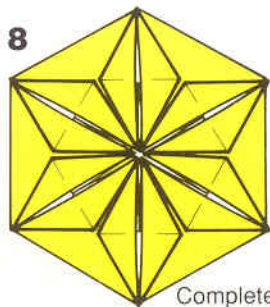
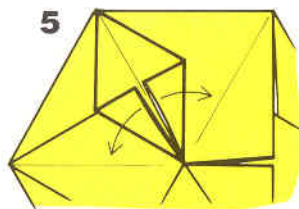
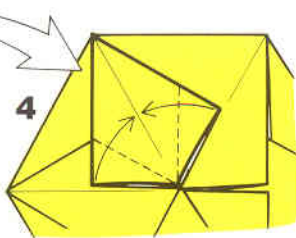
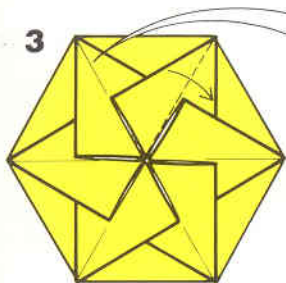

Completed.

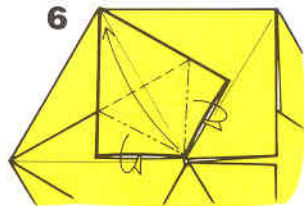
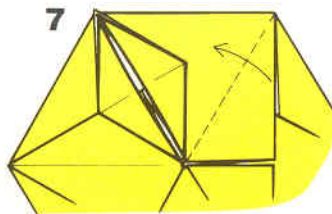

Do the same with the other five flaps.

REINDEER

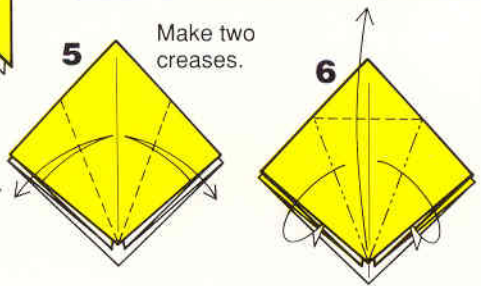
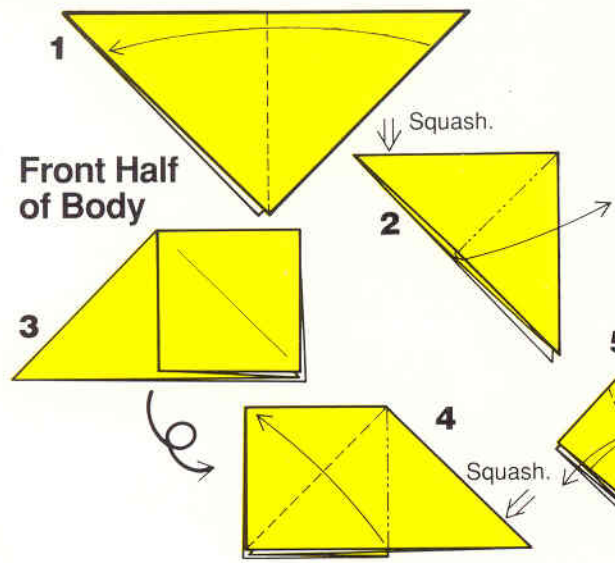

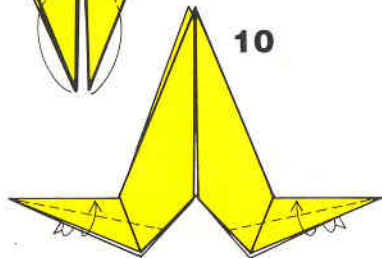
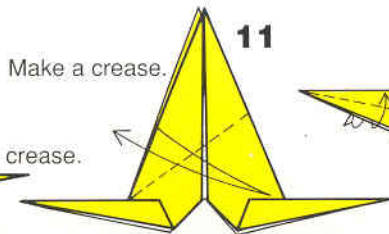
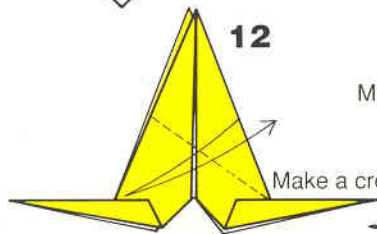
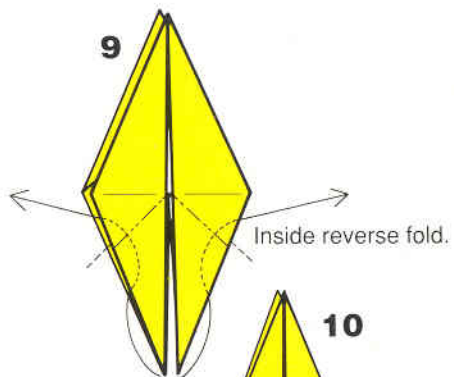
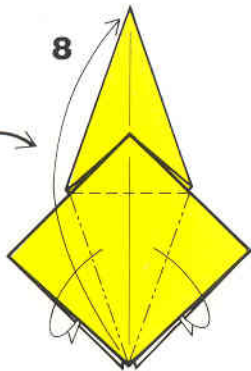
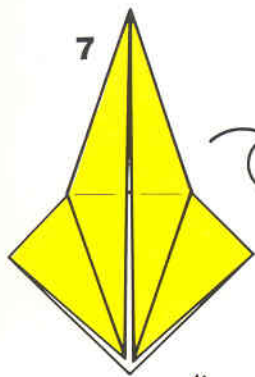

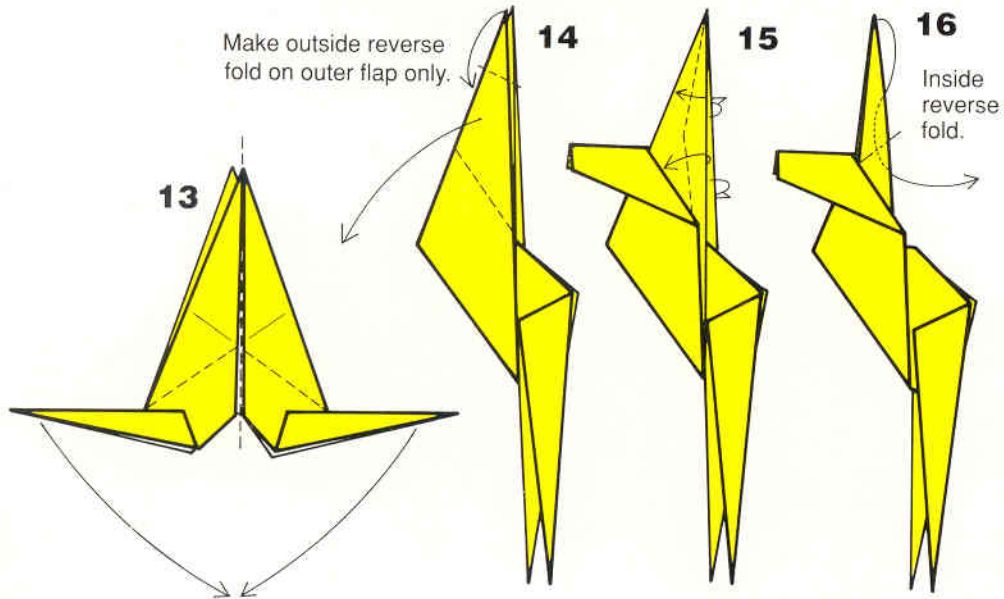

17

Inside reverse fold three times.

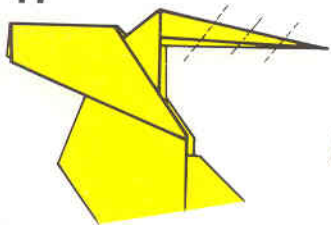

18

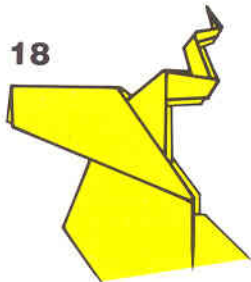

19

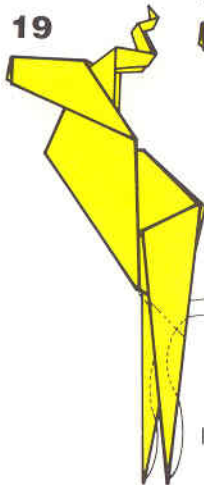

20

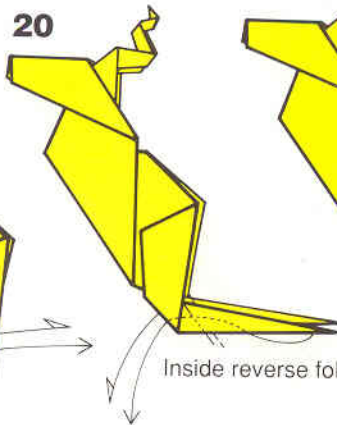

Inside reverse fold.

Inside reverse fold.

21

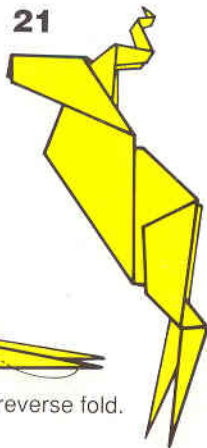

Begin with step 9
of the front half.

Rear Half of Body

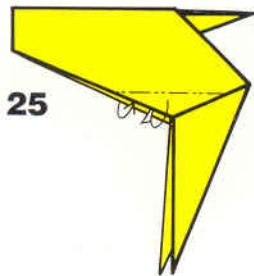
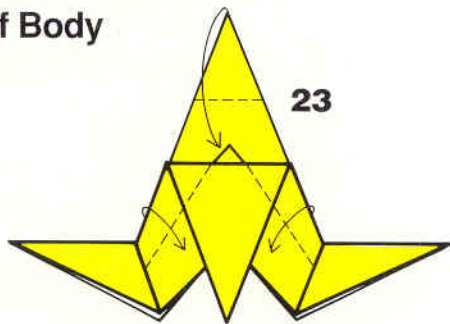
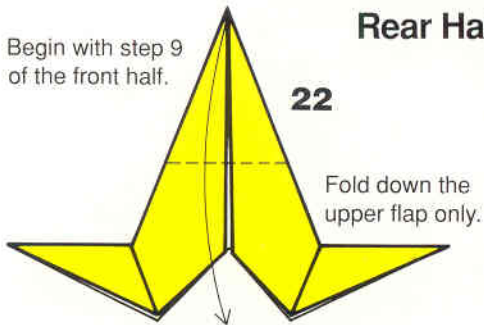

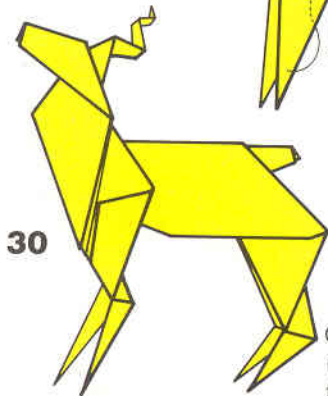
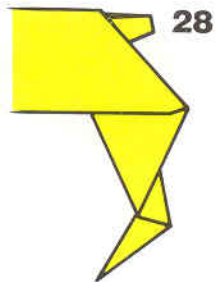
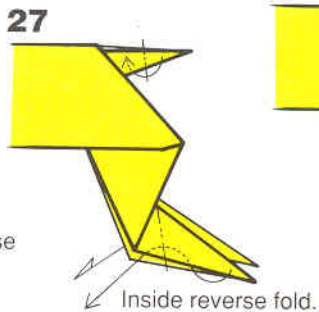
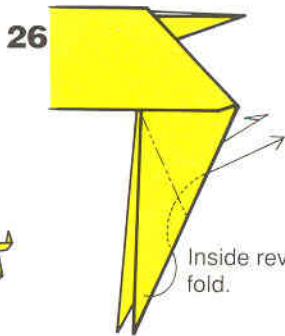

Completed.
(To make a harness as shown on
the package, cut strips of paper.)

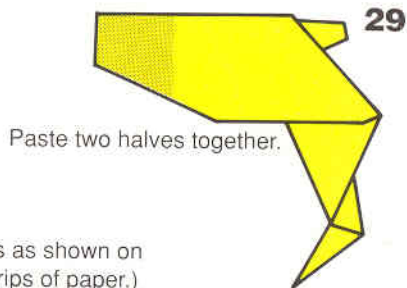

SANTA CLAUS

(Created by Jun Maekawa)

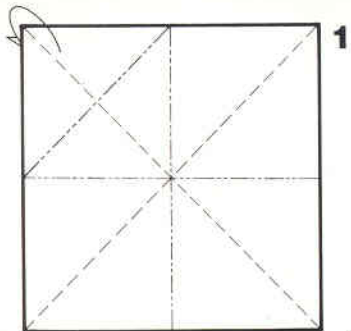

Make four creases and
fold one corner behind.

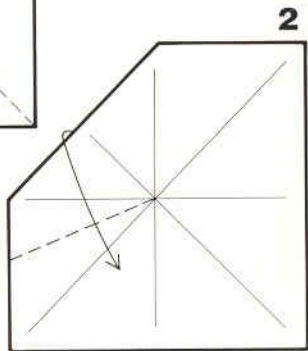

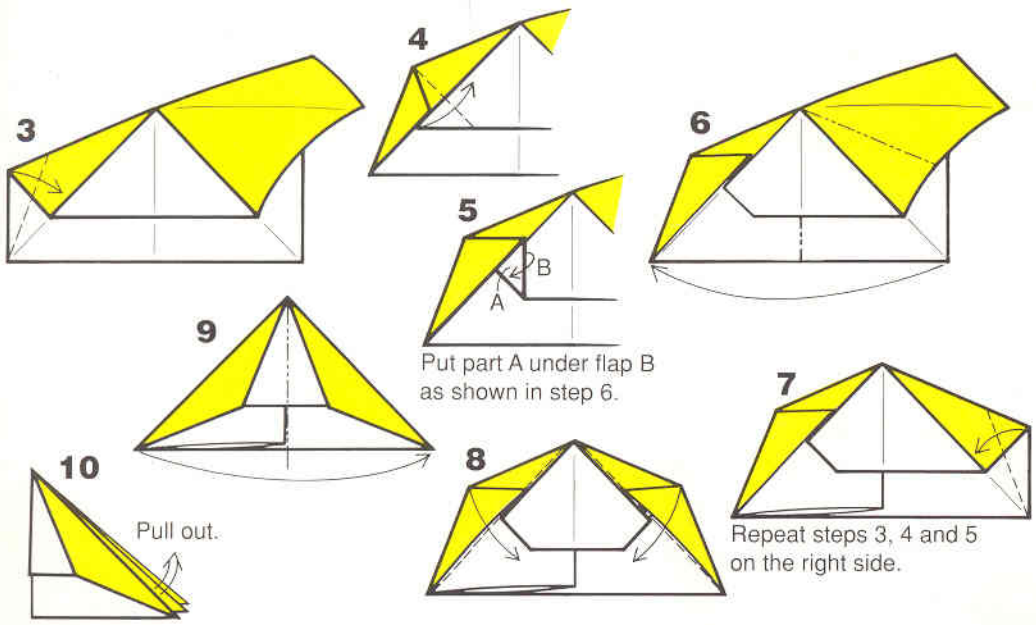

Put part A under flap B as shown in step 6.

Repeat steps 3, 4 and 5 on the right side.

Pull out the white triangle
as shown in step 12.

↓ Squash.

11

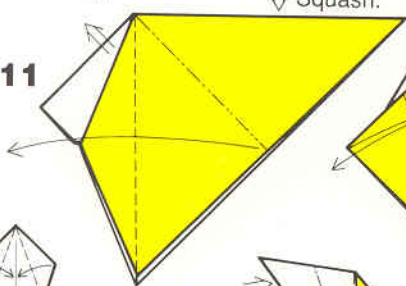

Make two
creases.

12

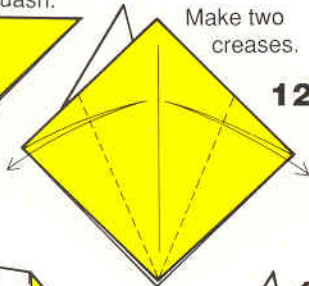

13

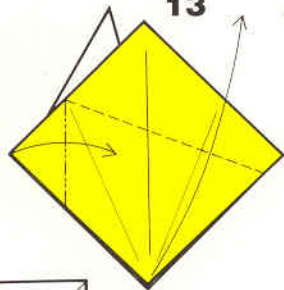

Squash.

15



14

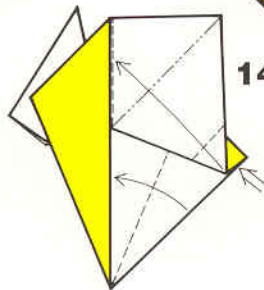

16

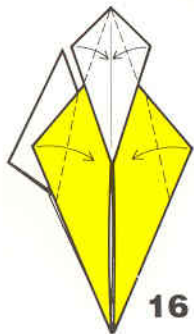

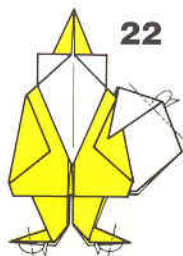
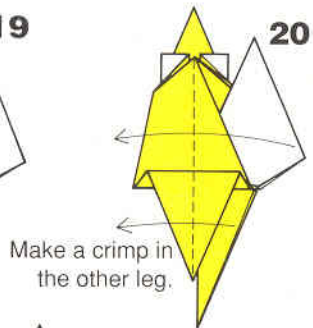
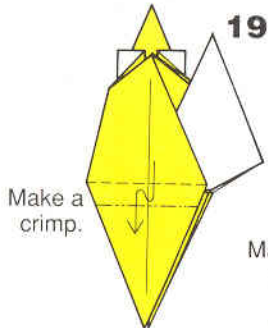
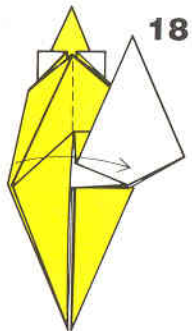

Fold tip of each foot under.

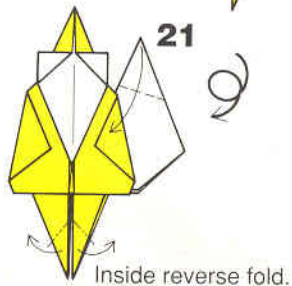

SLED

(Created by Luigi Leonardi)

1

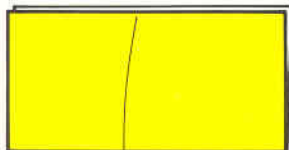

Make a crease.



2

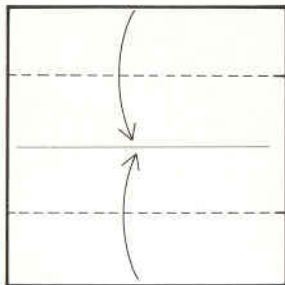

3



Make a crease.

4

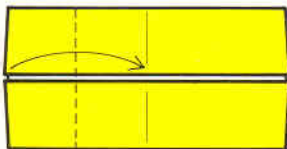

5

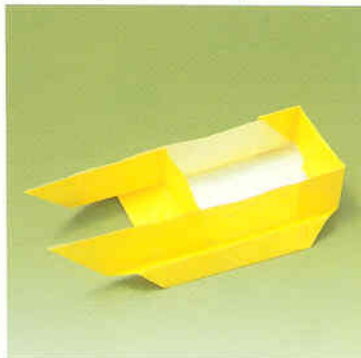
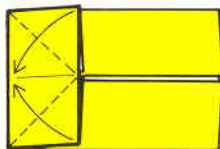

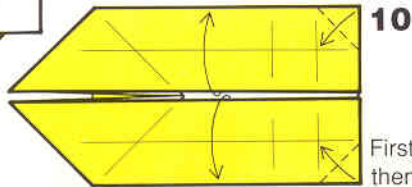
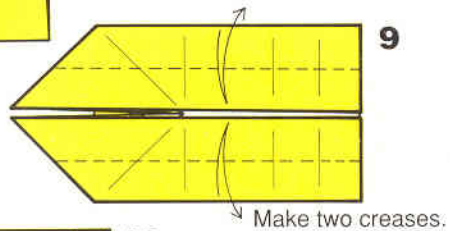
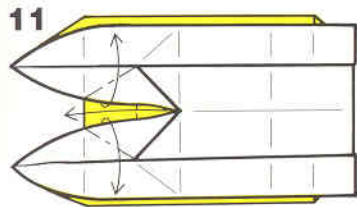
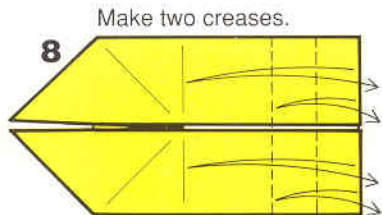
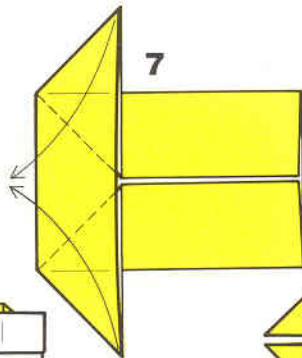
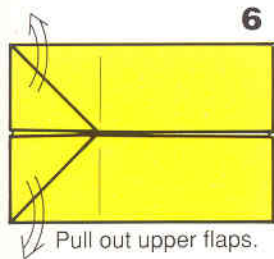

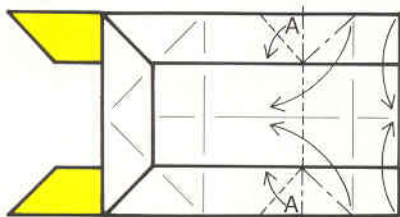
12

First fold at A.

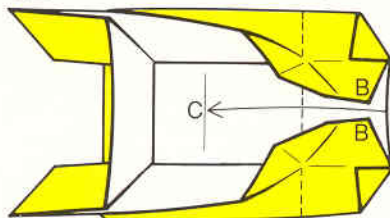
13

Bring two outer corners B together at center. Fold B over to touch C.

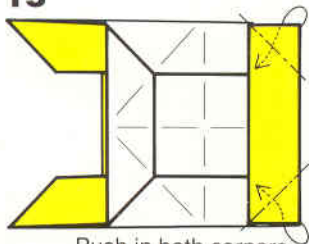
15

Push in both corners.

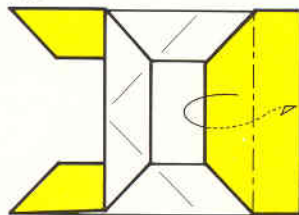
14

Fold flap over and tuck in.

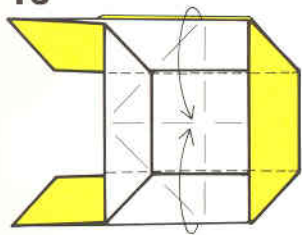
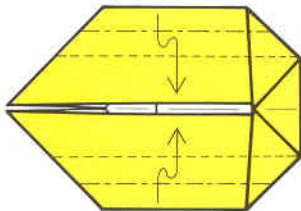
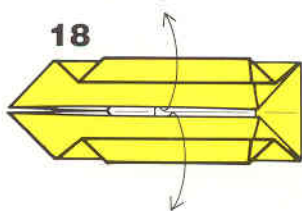
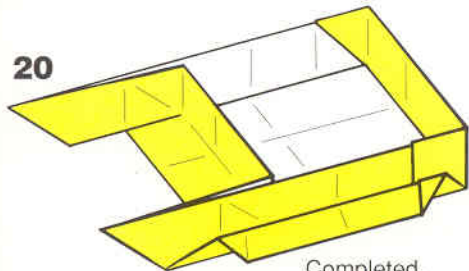
16**17****18****20**

Completed.

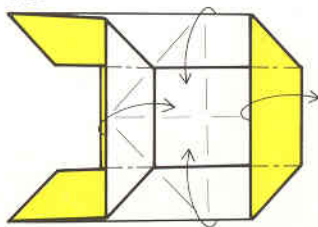
19

PENTAGON

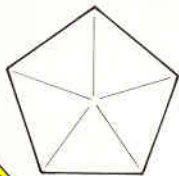
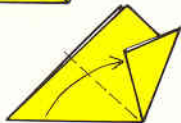
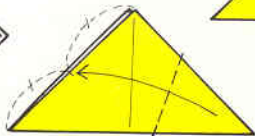
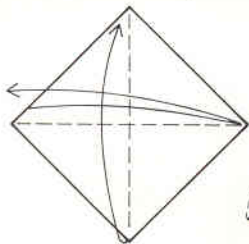

Cut off so that a right angle will be formed at A.

HEXAGON

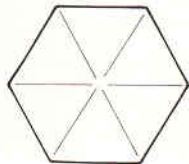
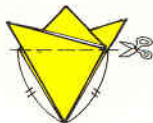
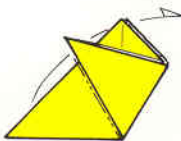
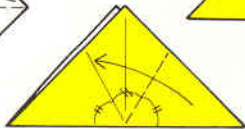
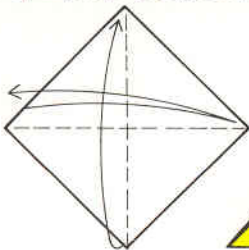

Cut off at dotted line.

CONTENTS

Candy Stick	3	Angel	29
Snowman	5	Holly	31
Party Bow	7	Gift Box	35
Candle	9	Star	37
Christmas Stocking	11	Flower	39
Balloon	13	Pinwheel	41
Bell	15	Snowflake	45
Christmas Tree	17	Reindeer	47
Paper Chain	19	Santa Claus	53
Church	23	Sled	57
Heart	25	Pentagon and	
Pony	27	Hexagon	61

SHUFUNOTOMO/JAPAN PUBLICATIONS

Printed in Japan

